

Recommendation of the Executive Director and assessment of cultural heritage significance under Part 3 of the *Heritage Act 2017*



Current Name	Fitzroy Cricket Ground Grandstand
Location	Brunswick Street, Fitzroy North, Yarra City Council
Date Registered	27 June 1990
VHR Number	VHR H0751
VHR Category	Registered Place
Hermes Number	447



Fitzroy Cricket Ground Grandstand (February 2020)

EXECUTIVE DIRECTOR RECOMMENDATION TO THE HERITAGE COUNCIL:

That the Heritage Council amends the existing registration of VHR H0751 in accordance with s.62 of the *Heritage Act 2017* by:

1. Including additional land under s.49(1)(d)(i) and (ii).
2. Determining categories of works or activities which may be carried out in relation to the Fitzroy Cricket Ground Grandstand for which a permit is not required (permit exemptions), under s.49(3).

STEVEN AVERY
Executive Director

Recommendation Date: Monday 16 March 2020

Advertising Period: Friday 20 March – Monday 18 May 2020

This recommendation report has been issued by the Executive Director, Heritage Victoria under s.37 of the *Heritage Act 2017*.

Current Name: Fitzroy Cricket Ground Grandstand

VHR number: VHR H0751

Hermes number: 447

REASONS FOR REGISTRATION IN JUNE 1990

The State-level historical and architectural cultural heritage significance of the Fitzroy Cricket Ground Grandstand was recognised in June 1990 by its inclusion in the Register of Historic Buildings (VHR H0751). The registration recognised the place's historical significance as an early surviving grandstand with associations with the development of cricket and Australian Rules football in metropolitan Melbourne. It also recognised its architectural significance as a fine example of a nineteenth-century timber grandstand.

AMENDMENT APPLICATION MADE ON 11 MARCH 2020

On 11 March 2020 the Executive Director made and accepted an application to amend the registration of the Fitzroy Cricket Ground Grandstand (VHR H0751) by including additional land and permit exemptions. The Executive Director is systematically reviewing early registrations and amending as required to ensure that they are consistent with current practices under the *Heritage Act 2017*. The Executive Director is also proposing to convert the existing statement of significance to the current format.

AMENDMENT RECOMMENDATION REASONS

The Executive Director recommends that the Heritage Council amend this registration in accordance with s.62 of the *Heritage Act 2017* because under s.32(1) of the Act he considers that—

- a) the State-level cultural heritage significance of the place would be substantially less if the land or any part of the proposed land for inclusion in the Register was developed;
- b) the proposed land for inclusion in the Register is important to the protection or conservation of the place or contributes to the understanding of the place.

WHO ARE THE TRADITIONAL OWNERS/REGISTERED ABORIGINAL PARTY FOR THIS PLACE?

The Registered Aboriginal Party under the *Aboriginal Heritage Act 2006* for the land on which the Fitzroy Cricket Ground Grandstand is located is the Wurundjeri Woi Wurrung Cultural Heritage Aboriginal Corporation.

RECOMMENDED EXTENT OF REGISTRATION

All of the place shown hatched on Diagram 751 encompassing part of Allotment 6 Section 34 at North Fitzroy, Parish of Jika Jika.

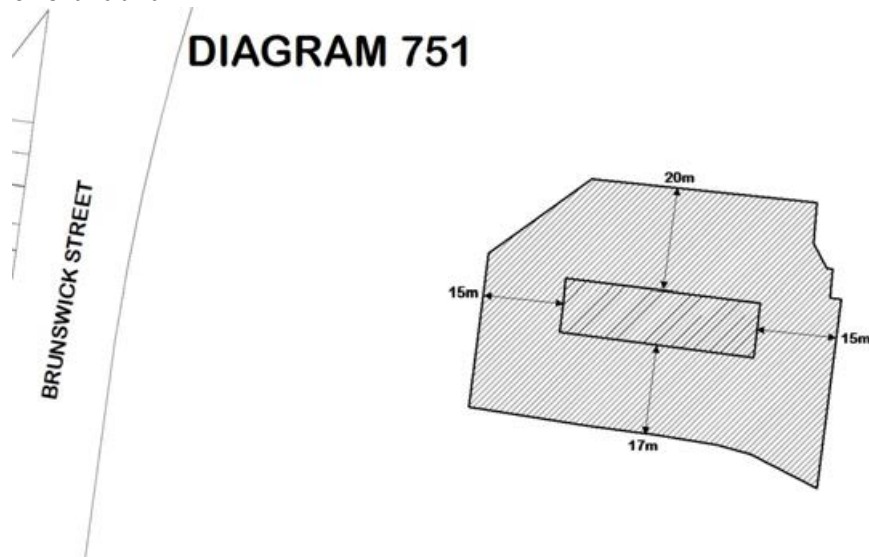

The extent of registration of the Fitzroy Cricket Ground Grandstand in the Victorian Heritage Register affects the whole place shown on Diagram 751 including the land, buildings (including the exteriors and interiors), building features and fixtures, grassed areas, trees, paved areas, landscape elements and other features.

AERIAL PHOTO SHOWING RECOMMENDED EXTENT



Current Name: Fitzroy Cricket Ground Grandstand
VHR number: VHR H0751
Hermes number: 447

RATIONALE FOR EXTENT

The recommended extent of registration comprises the significant grandstand building, the 1980s community room to the east of the grandstand and land occupied by these buildings. It also includes land to provide a setting.

CHANGE OF HERITAGE CATEGORY

No change of category.

CHANGE OF NAME

No change of name.

BACKGROUND

WHAT IS AT THE PLACE?

The Fitzroy Cricket Ground Grandstand (1888) is located on the north side of the WT Peterson Oval (commonly known as the Brunswick Street Oval) within the Edinburgh Gardens precinct. It comprises timber framed seating area atop a brick storey containing change rooms and other facilities. The southern elevation, facing the oval, features a central divided entry stair, additional stairs to each end of the building, cast iron balustrading to the seating area and small central gable with louvered vent. The western elevation has an attached verandah. A single-storey community meeting room (1980s) is located to the east of the grandstand. The north elevation is of painted brick and weatherboard and includes windows to both the upper and lower levels. The area surrounding the buildings consists of asphalted paths and roadways, areas of lawn and trees.

WHAT IS THE HISTORY OF THE PLACE?

The site for the Edinburgh Gardens was reserved in 1862. In the same year, cricket teams were given permission to occupy part of the reserve and began to introduce improvements to support the use of the place for sports. The Fitzroy Football Club was formed in 1883 and began playing at the ground. Cricket and Australian Rules football continued to grow in popularity in the late nineteenth century, and in 1888 the cricket club had the resources to commission the construction of the Fitzroy Cricket Ground Grandstand. The grandstand was designed by Nathaniel Billing, then working as N. Billing and Son. In 1905 an additional grandstand, similar in design, was constructed to the west of the 1888 grandstand. In 1966, the Fitzroy Football Club vacated the ground. In the 1970s, the 1905 grandstand was destroyed by fire. After a period of neglect, the surviving 1888 grandstand was refurbished, and additional community facilities added. Further works were undertaken in the early 1990s and 2000s. In 2020 the grandstand was home to sports teams including the Edinburgh Cricket Club and Fitzroy Football Club.

STATEMENT OF SIGNIFICANCE

WHAT IS SIGNIFICANT?

The Fitzroy Cricket Ground Grandstand building including its fixtures and fittings. The 1980s Community Room to the east of the grandstand is not significant.

HOW IS IT SIGNIFICANT?

The Fitzroy Cricket Ground Grandstand is of architectural and historical significance to the State of Victoria.

The place satisfies the following criteria for inclusion in the Victorian Heritage Register:

- Criterion A: Importance to the course, or pattern, of Victoria's cultural history
- Criterion D: Importance in demonstrating the principal characteristics of a class of cultural places/objects.

WHY IS IT SIGNIFICANT?

The Fitzroy Cricket Ground Grandstand is historically significant as one of the earliest surviving nineteenth-century grandstands in the metropolitan area. Constructed in 1888, the Fitzroy Cricket Ground Grandstand has an enduring association with the development of Australian rules football and cricket and their growth as popular recreational pastimes from the late nineteenth century onwards. The ground was the home of the Fitzroy Football Club from 1884 until 1966 and the Grandstand remains as an important reminder of the contribution made by Fitzroy to the history of Australian rules football in Victoria (Criterion A).

The Fitzroy Cricket Ground Grandstand is architecturally significant as a fine and intact example of a nineteenth-century timber grandstand. It was designed by noted architect Nathaniel Billing and exhibits high quality design characteristics in its symmetrical composition and restrained decorative details. Many grandstands constructed in this era have been demolished or substantially altered and it remains a comparatively intact surviving example (Criterion D).

INTRODUCTION TO PERMIT EXEMPTIONS

Preamble

The purpose of this information is to assist owners and other interested parties when considering or making decisions regarding works to a registered place. It is recommended that any proposed works be discussed with an officer of Heritage Victoria prior to making a permit application. Discussing proposed works will assist in answering questions the owner may have and aid any decisions regarding works to the place.

The extent of registration of the Fitzroy Cricket Ground Grandstand in the Victorian Heritage Register affects the whole place shown on Diagram 751 including the land, buildings (exteriors and interiors), roads, trees, landscape elements and other features. Under the *Heritage Act 2017* a person must not remove or demolish, damage or despoil, develop or alter or excavate, relocate or disturb the position of any part of a registered place or object without approval. It is acknowledged, however, that alterations and other works may be required to keep places and objects in good repair and adapt them for use into the future.

If a person wishes to undertake works or activities in relation to a registered place or registered object, they must apply to the Executive Director, Heritage Victoria for a permit. The purpose of a permit is to enable appropriate change to a place and to effectively manage adverse impacts on the cultural heritage significance of a place as a consequence of change. If an owner is uncertain whether a heritage permit is required, it is recommended that Heritage Victoria be contacted.

Permits are required for anything which alters the place or object, unless a **permit exemption** is granted. Permit exemptions usually cover routine maintenance and upkeep issues faced by owners as well as minor works or works to the elements of the place or object that are not significant. They may include appropriate works that are specified in a conservation management plan. Permit exemptions can be granted at the time of registration (under s.38 of the *Heritage Act*) or after registration (under s.92 of the *Heritage Act*). It should be noted that the addition of new buildings to the registered place, as well as alterations to the interior and exterior of existing buildings requires a permit, unless a specific permit exemption is granted.

Disrepair of registered place or registered object

Under s.152 of the Act, the owner of a registered place or registered object must not allow that place or object to fall into disrepair.

Failure to maintain registered place or registered object

Under s.153 of the Act, the owner of a registered place or registered object must not fail to maintain that place or object to the extent that its conservation is threatened.

Conservation management plans

It is recommended that a Conservation Management Plan is developed to manage the place in a manner which respects its cultural heritage significance.

Aboriginal cultural heritage

If works are proposed which have the potential to disturb or have an impact on Aboriginal cultural heritage it is necessary to contact Aboriginal Victoria to ascertain any requirements under the *Aboriginal Heritage Act 2006*. If any Aboriginal cultural heritage is discovered or exposed at any time it is necessary to immediately contact Aboriginal Victoria to ascertain requirements under the *Aboriginal Heritage Act 2006*.

Other approvals

Please be aware that approval from other authorities (such as local government) may be required to undertake works.

Archaeology

There is no identified archaeology of state level significance at the place.

Cultural heritage significance***Overview of significance***

The cultural heritage significance of the Fitzroy Cricket Ground Grandstand lies in the grandstand building, attached features and fixtures and its relationship to the oval and broader context. The 1980s community room to the east of the grandstand is not significant. Other recreational facilities introduced in the late-twentieth century such as the bocce court are not significant.

CATEGORIES OF WORKS OR ACTIVITIES (PERMIT EXEMPTIONS) RECOMMENDED UNDER S.38

The following works do not require a permit provided that they are carried out in a manner which does not harm the cultural heritage significance of the Fitzroy Cricket Ground Grandstand.

General Conditions

- All exempted alterations are to be planned and carried out in a manner which prevents damage to the significant fabric of the Fitzroy Cricket Ground Grandstand.
- Should it become apparent during further inspection or the carrying out of works that original or previously hidden or inaccessible details of the Fitzroy Cricket Ground Grandstand are revealed which relate to the significance of the place or object, then the exemption covering such works shall cease and Heritage Victoria shall be notified as soon as possible.
- All works should ideally be informed by a Conservation Management Plan prepared for the place. The Executive Director is not bound by any Conservation Management Plan, and permits still must be obtained for works suggested in any Conservation Management Plan.
- Nothing in this determination prevents the Heritage Council from amending or rescinding all or any of the permit exemptions.
- Nothing in this determination exempts owners or their agents from the responsibility to seek relevant planning or building permits from the relevant responsible authority, where applicable.

Specific Permit Exemptions**Grandstand***Exterior*

- Minor repairs and maintenance which replaces like with like. Repairs and maintenance must maximise protection and retention of significant fabric and include the conservation of existing details or elements. Any repairs and maintenance must not exacerbate the decay of fabric due to chemical incompatibility of new materials, obscure fabric or limit access to such fabric for future maintenance.
- Repair to or removal of items such as air conditioners, pipe work, ducting, wiring, antennae and aerials.
- Works or activities, including emergency stabilisation, necessary to secure safety in an emergency where a structure or part of a structure has been irreparably damaged or destabilised and poses a safety risk to its users or the public. Note: The Executive Director, Heritage Victoria, must be notified within seven days of the commencement of these works or activities.

- Painting of previously painted surfaces in the same colour, finish and product type provided that preparation or painting does not remove earlier paint finishes or schemes. Note: This exemption does not apply to decorative finishes or unpainted, oiled or varnished surfaces.
- Cleaning including the removal of surface deposits or graffiti by the use of low-pressure water (less than 300 psi at the surface being cleaned) and neutral detergents and mild brushing and scrubbing with plastic not wire brushes.
- Repair and maintenance to existing signage and replacement of signage where it is to the same scale and in the same location.
- Repair to and removal of existing exterior lighting and public address systems.

Interior

- Painting of previously painted surfaces in the same colour, finish and product type provided that preparation or painting does not remove earlier paint finishes or schemes. Note: This exemption does not apply to decorative finishes or unpainted, oiled or varnished surfaces.
- Removal or replacement of devices for the hanging of wall mounted artworks, noticeboards and signage in existing locations.
- Installation, removal or replacement of carpets and/or flexible floor coverings and window furnishings such as curtains and blinds.
- Removal or replacement of smoke and fire detectors, alarms and the like, of the same size and in existing locations.
- Repair, removal or replacement of existing ducted, hydronic or concealed radiant type heating provided that the central plant is concealed, and that the work is done in a manner which does not alter building fabric.
- Installation of plant within the roof space, providing that it does not impact on the external appearance of the building or involve structural changes.

1980s Community Rooms

All the works and activities specified for the Grandstand, plus:

- All works to the interior of the Community Room.

Events

- The installation and/or erection of temporary elements associated with authorised short-term events provided they are not attached to the grandstand building and are in situ for a maximum period of 30 days after which time they must be removed. This includes:
 - Temporary structures such as marquees.
 - Temporary security fencing, scaffolding, hoardings or surveillance systems.
 - Temporary infrastructure, including lighting, portable toilets, public address systems and the like to support events and performances.
 - Temporary micro tenancies such as food trucks and the like, with ground protection.
 - Temporary operational equipment such as freestanding wayfinding/directional signage.

Landscape/ outdoor areas

- The processes of gardening including mowing, pruning, mulching, bedding displays, removal of dead shrubs, planting and replanting of garden beds, disease and weed control and maintenance to care for existing plants.
- Management and maintenance of trees including formative and remedial pruning, removal of deadwood and pest and disease control.
- The removal or pruning of dead or dangerous trees to maintain safety.

- Establishment of new garden beds and low-level plantings except where this involves major excavation.
- Installation of new pathways where they do not involve major excavation or interface with the fabric of the grandstand.
- Subsurface works involving the installation, removal or replacement of existing watering and drainage systems or other services provided there are no visible above ground elements. Existing lawns, gardens and hard landscaping, including paving, footpaths and roadways are to be reinstated on the completion of works.
- Repair and maintenance of existing hard landscaping including paving, footpaths and roadways where fabric, design, scale, form and method of fixing is repaired or replaced like for like.
- Repair, maintenance or removal of bocce court.
- Removal or replacement of external directional or informational signage provided the size, location and material remains the same.
- Maintenance, repair and replacement of existing services such as plumbing, electrical cabling, surveillance systems, external lighting, pipes or fire services which does not involve changes in location or scale of above ground elements, or major excavation.
- Maintenance, repair and removal of the existing water tank, bins, bin cages, benches, bollards and fencing and replacement of these items provided they are of the same scale and in the same location.

ATTACHMENT 1

EXISTING REGISTRATION DETAILS

EXISTING CATEGORY OF REGISTRATION

Registered Place.

EXISTING EXTENT OF REGISTRATION

AMENDMENT OF REGISTER OF HISTORIC BUILDINGS

Historic Building No. 751.

Fitzroy Cricket Ground Grandstand, Brunswick Street, Fitzroy.

To the extent of the Grandstand building which is located on land permanently reserved as a site for a public park and garden, more particularly described in an Act relating to certain lands at Fitzroy, No. 7627(1967), First Schedule.

[Victoria Government Gazette No. G25 27 June 1990 pp.1970-1971]

No extent diagram accompanies this registration.

EXISTING STATEMENT OF SIGNIFICANCE

What is significant?

The Fitzroy Cricket Ground Grandstand was constructed in 1888 to the design of the architects N Billing and Son. It is of typical nineteenth century form with central divided entry stair emphasised by a small pediment and restrained use of cast iron for balustrading. The ground, usually known as the 'Brunswick Street Oval', was the home of the Fitzroy Football Club until 1966.

How is it significant?

The Fitzroy Cricket Ground Grandstand is of architectural and historical significance to the State of Victoria.

Why is it Significant?

The Fitzroy Cricket Ground Grandstand is of architectural significance as a fine example of a 19th century timber grandstand at a major sports venue. It is of typical 19th century form with central divided entry stair emphasised by a small pediment and restrained use of cast iron for balustrading only. Grandstands were a spectacular feature of nineteenth century recreation but generally were demolished or severely altered. The Fitzroy Cricket Ground Grandstand therefore stands as one of the most important of a now small group of survivors.

The Fitzroy Cricket Ground Grandstand is of historical significance as possibly the oldest and most intact nineteenth century grandstand in the metropolitan area and for its enduring association over many years with inner metropolitan football and cricket, one of the few associated structures to have survived relatively intact. The Cricket Ground was the home of the now-defunct Fitzroy Football Club until 1966 and stands as an important reminder of the contribution made by Fitzroy to the history of Australian football in Victoria.

EXISTING PERMIT EXEMPTIONS

There are currently no permit exemptions.